

DAIKIN

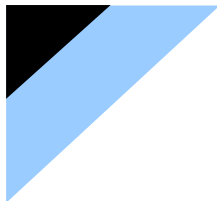

No. AT04C024E
November.24.2005

SPECIFICATIONS

COMPRESSOR

MODEL : JT95GBBY1L

1. Range of Application and Assembly

1-1 Applied Range

The specifications provided here apply to the JT95GBBY1L Hermetic Scroll Compressor.

1-2 Range of Assembly

	Name	Quantity	Plan No.	Remarks
1	Compressor	1	DA427—2110	Including lubricant
2	Anti-vibration Rubber	4	DA429—903—1	
3	Spacer	4	DA429—903—2	

Note: The pressure units in these specifications refer to the gauge pressure, unless stated otherwise.

2. Main Specifications

2-1 Main Ratings

型 号		JT95GBBY1L
Rated Output	kW	2.2
Number of Poles	—	2
Displacement	cm ³ /rev	49.4
Rated Speed (=Nominal Revolution)	r/min	2900 [50Hz]
Lubricant	—	DAPHNE FVC68D
Lubricant (Volume)	cm ³	1200
Refrigerant	—	R407C
Inlet Pipe (I.D.)	mm	22.1 ~ 22.25 (Steel Pipe 20# Tinned Copper)
Outlet Pipe (I.D.)	mm	16 ~ 16.15 C122OT—O
External Cable Terminal	—	AMP 42232-3
Weight (including refrigeration oil)	kg	29
Power Supply	—	3 phase at 50Hz
Rated Voltage	V	380

3. Quality Specifications

3-1 Appearance and Dimensions

- The entire surface of the compressor has been coated with black paint (dipping and quick-dry painting). (Coating membrane pressure of at least 15 μ m)
- Outer dimensions are shown on the attached diagrams of the exterior.

3-2 Leak Test and Pneumatic Resistance Test

The leak and pneumatic resistance tests of the compressor are conducted under the following conditions.

	Low-pressure side [MPa]	High-pressure side [MPa]
Leak Test	1.6	3.0
Pneumatic Resistance Test	10.5	10.5

3-3 Compressor Characteristics

Frequency	Voltage	Refrigerating Capacity	Input	Current	COP	Sound Pressure	Vibration
[Hz]	[V]	[kW]	[kW]	[A]	W/W	[dBA]	[μm]
50	380	9.16	2.86	4.90	3.2	61 max.	50 max.

Note 1. The above characteristics are satisfied under the following operating conditions (ASRE/T).

Evaporating Temperature [°]	Condensing Temperature [°]	Superheating Degree [°]	Super-cooling Degree [°C]
7.2	54.4	11.1	8.3

- The refrigerating capacity and COP fluctuate within a range above 95%.
The Input and Current fluctuate within a range between 95% and 105%.
- The sound pressure value is measured for the position one meter in front of the compressor at a height half, in use Daikin' s genuine rubber mounting.
- The vibration value is measured at the compressor legs attached, in use Daikin's genuine.

3-4 Starting Characteristic

- Starting Current : 39A (380V/50Hz、 LRA)
- Starting Voltage : Minimum terminal voltage of 323V (50Hz)
- Starting Pressure : 1.77Mpa (high pressure, Max.)

3-5 Motor Characteristic

- Coil Resistance : 4.85 (average) at 20

3-6 Electric Characteristic

- Insulation Resistance :30 M min. (when dry), 1 M min. (when refrigerant flood the compressor.)
- Withstand Voltage : 2,400 VAC for 1 sec. and no dielectric breakdown impress
- Leakage Current : 0.75 mA/ kW Max.

3-7 Others

- Moisture content : 300 mg Max.
- Residual oil : 2000ppm max. (for the standard oil charge of 1200cm³)
- Residual chlorine amount : 15ppm max.(for the standard oil charge of 1200cm³)
- Residue : 50 mg Max.
- The compressor is filled up with nitrogen gas at a pressure of 0.01MPa before shipping.

4. Compressor Operating Range**4-1 Operating Range**

Refer to page 7 for the Compressor's Possible Operating Range.

4-2 Precautions

1) Don't drive under air condition, otherwise may cause the compressor explosion.

2) Temperature

- Discharge port temperature : 130 Max.
- Discharge gas temperature range : 120 Max.
- Oil temperature : 120°C Max.
- Motor winding temperature : 125°C Max. (Average temperature based up on resistance measure of motor coil)

3) Power Supply

- Maximum voltage fluctuation : ±10% of rated voltage
- Phase imbalance : ± 2.5%
- Maximum frequency fluctuation : ±2% of rated frequency

4) Refrigerant Systems

- Allowable refrigerant charge : 1.5 kg

Liquid compression and liquid impact : No

- The compressor may be filled with an excessive refrigerant charge, provided that circuit design is conducted with an appropriate device, such as an accumulator, is employed so that the compression mechanism will be free of excessive refrigerant. Please estimate liquid or impart by unwonted sound of the compressor.
- Be sure to keep the discharge port temperature upon condensing temperature.
- Oil concentration in oil sump during operation: 35wt% Min.
- The compressor must be filled with refrigerant through the liquid pipe.

If the liquid height of residual compressor oil and refrigerant maintained in the compressor above external bottom higher than 244mm, the part of terminal will immerse in the liquid of residual compressor oil and refrigerant. In that case, insulation resistance of the compressor will fall. Therefore, please design the refrigerant pipeline so that liquid height of residual compressor oil and

refrigerant maintained in the compressor above external bottom lower than 244mm.

- Design the refrigerant pipeline so that the oil in pipeline return to compressor rapidly.
- Make sure that the moisture content in liquid refrigerant under 75ppm.
- Counter pressure (i.e. Suction pressure – discharge pressure) at pneumatic or leak test
 - : 1.47MPa Max.
- Maximum operating times : 12 per hour Max.

Make sure that the shortest operation period is two minutes or more. Be sure to wait for at least three minutes to start the compressor after turning it off.

- Mounting Angle : $\pm 10^\circ$ Max.
- Be sure to employ a crankcase heater. The recommendable output is 33 W.
- Liquid height of residual compressor oil during operation should be maintained in the compressor external bottom at, at least, 27mm.

5) The control of the residue inside the refrigerating system

- Allowable water content : 150ppm max. (in liquid refrigerant)
- Allowable air infiltration amount : 500ppm max. (charged oil weight ratio)
- Allowable chlorine amount : 25ppm max. (charged oil weight ratio)
- Ester oil infiltration : 6000ppm max.(charged oil weight ratio)
- Although oil remaining in air conditioner system is recommended to be at 6000 ppm below, capillary jam test should be done. If not, our company are not responsible for the breakdown such as capillary jam etc, we kindly hope you comprehend and support.
- The accumulator and receptor must be cleaned, without press oil and rust-proof containing metals soap etc.
- Please apply the pipe and function parts (Such as four way valve and other parts)in which residue is controlled.(The residue means oil and solid remains)

5. Protection Devices

When the compressor is installed in an air-conditioner system, it must be installed with the following protection devices.

5-1 Discharge Pipe Thermostat

Attach a discharge pipe thermostat within 30 cm of the discharge pipe in order to prevent the temperature of the exhaust gas of the compressor from rising excessively due to overloading or gas supply interruption. The thermostat must be set at temperature less than the maximum stipulated in 4-2-2). (reference value: $120 \pm 0.5^\circ\text{C}$).

5-2 Low-Pressure Switch

Attach a low-pressure switch operating at a minimum pressure of 0 MPa(reference value: $0.02 \pm 0.02\text{MPa}$),in order to prevent the compressor from damage that may be caused by excessively low-pressure pumping.

5-3 Reverse-Phase Protector

The rotation of the compressor in the reverse direction is prohibited because the compressor may be damaged if rotated in the reverse direction. Attach a reverse-phase protector that detects the phase inversion of the compressor without operating the compressor.

5-4 Internal Motor Protector (that had already been installed in the compressor)

- Manufacturer : UBUKATA INDUSTRIES CO., LTD
- Model : UP18UA203-58D
- Temperature Characteristics : Open Temperature $170^\circ\text{C} \pm 5^\circ\text{C}$
: Close Temperature $70^\circ\text{C} \pm 10^\circ\text{C}$
- Electrical Characteristics : Power Supply Voltage 380V
: Power Supply Frequency 50Hz

: Trip Performance Specified In Page 10/19

: Maximum Electrical Capacity 75A(380V)

5-5 Over-current Relay

Over-current relay shall be installed in order to prevent compressors from accident that may be caused by over-current especially locked-current of compressor motor.

5-6 High Pressure Switch

In order to interrupt the operation of the compressor in the case of extraordinary pressure rises, attach a high-pressure switch that operates at the pressure values provided as leak test pressure values in 3-2. (Reference value:2.9 ~ 3.0MPa).

6. Deadening and Otherwise

The hot-proof temperature of deadening and otherwise entwining compressor must be upon 170°C.

The hot-proof temperature of scarfskin of power supply cable contacted with compressor must be upon the temperature of contacting position.

7.Performance Curves

Refer to the accessional datum.

8.Origins and Factory

Xi'an Daikin Qing'an Compressor Co., Ltd. (IN CHINA)

9.Possible Compressor Operating Range

- Refer to 9-5 on the following page for the possible compressor operating range.
- Possible operating range is divided into four areas (areas 1~4). The attendant conditions for each differ.
- Operate the compressor upon sufficient confirmation of the following attendant conditions, particularly for areas 2, 3 and 4.

9-1 Area 1

Observe the precautions in 4-2.

9-2 Area 2

Specifically confirm the following from the precautions in 4-2 :

- Discharge port temperature : 130 Max.
- Motor coil temperature : 125 Max.(average temperature based up on resistance measure of motor coil)
- Oil temperature : 120 Max.
- Oil concentration : 35wt% Min.

9-3 Area 3

Specifically confirm the following:

- Oil concentration : 35 wt% Min.
- Liquid compression : No liquid compression

9-4 Area 4

Specifically confirm the following:

- Continuous operating time : 10 minutes Max.
- Oil concentration : 35 wt% Min.
- Liquid compression : No liquid compression
- Discharge port temperature : 130 Max.
- Motor coil temperature : 125 Max.(average temperature based up on resistance measure of motor coil)

9-5 Possible Compressor Operating Range

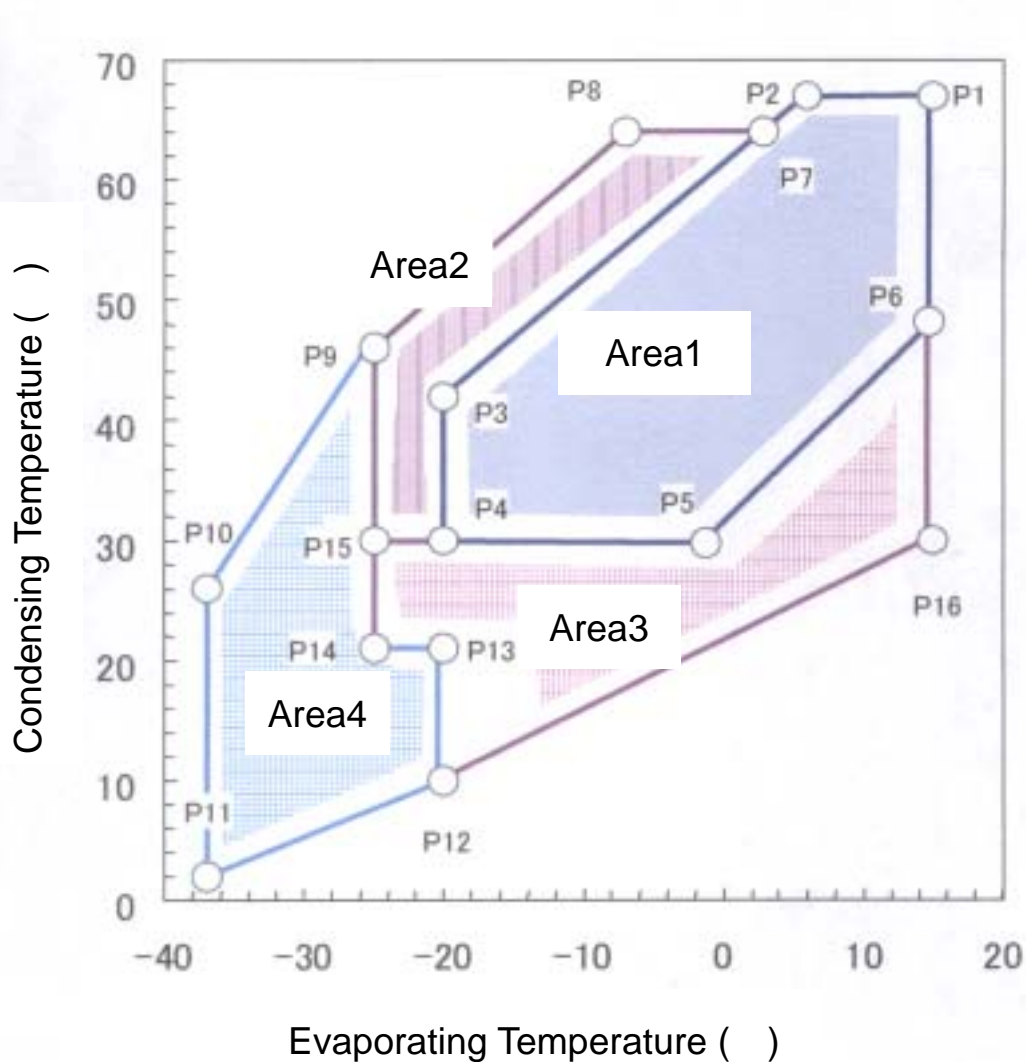

Point	P1	P2	P3	P4	P5	P6	P7	P8
Evaporating Temperature()	15	6	- 20	- 20	- 1	15	3	- 7
Condensing Temperature()	65	65	42	30	30	49	64	64

Point	P9	P10	P11	P12	P13	P14	P15	P16
Evaporating Temperature()	- 25	- 37	- 37	- 20	- 20	- 25	- 25	15
Condensing Temperature()	46	26	2	10	21	21	30	30

Nameplate

The nameplate on the compressor will appear as follows.



<Guide>

- | | |
|----------------|---------------------------------|
| • MODEL | A : Model Name |
| • POWER SOURCE | |
| V | B : Rated Voltage |
| PHASE | C : Phase number |
| Hz | D : Rated frequency |
| • MFG.NO. | E : Manufacturing number |

Terminal Position Indication

Compressor terminal box cover express position of terminal as follow fig.

Terminal box cover express position of three phase and single-phase compressor terminal.

The following pattern is eye view of compressor terminal position.

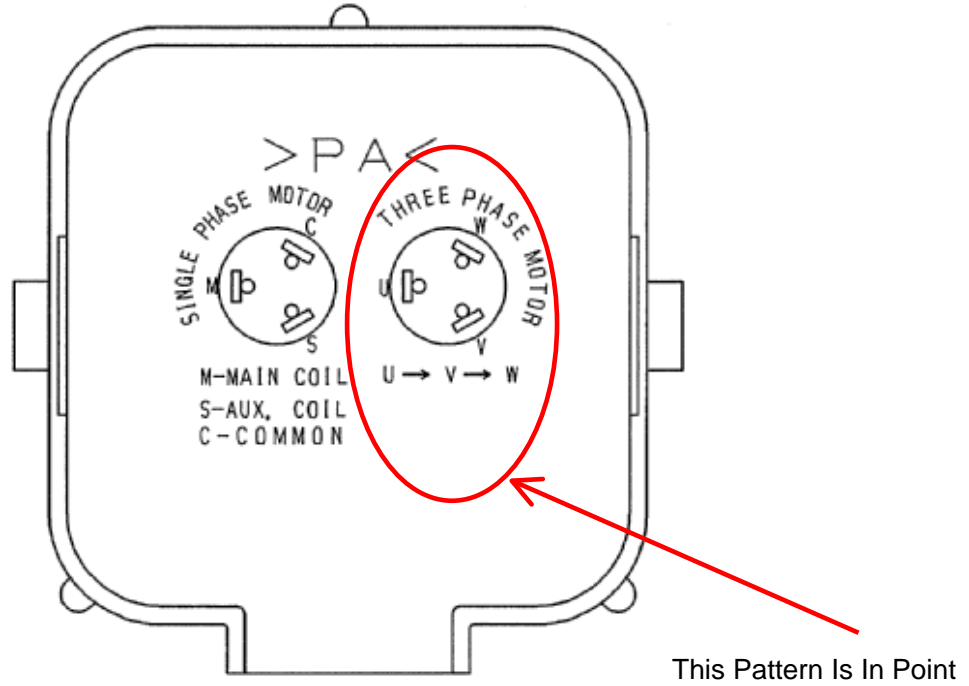

Earthing Terminal Position

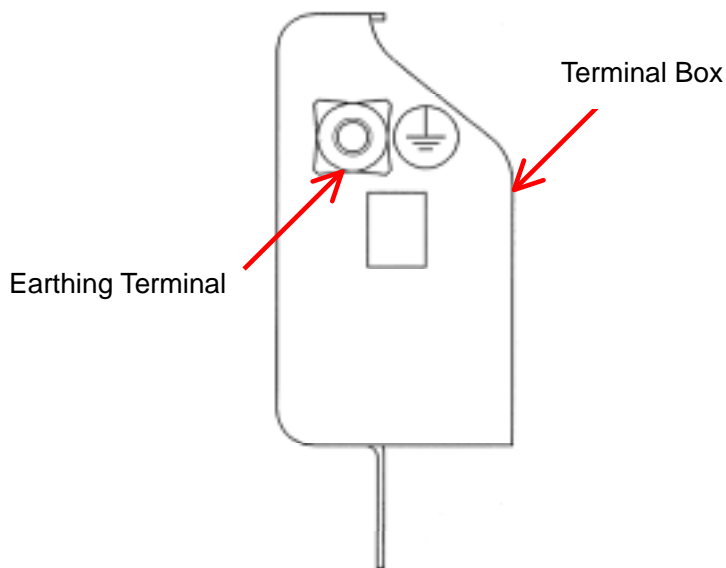

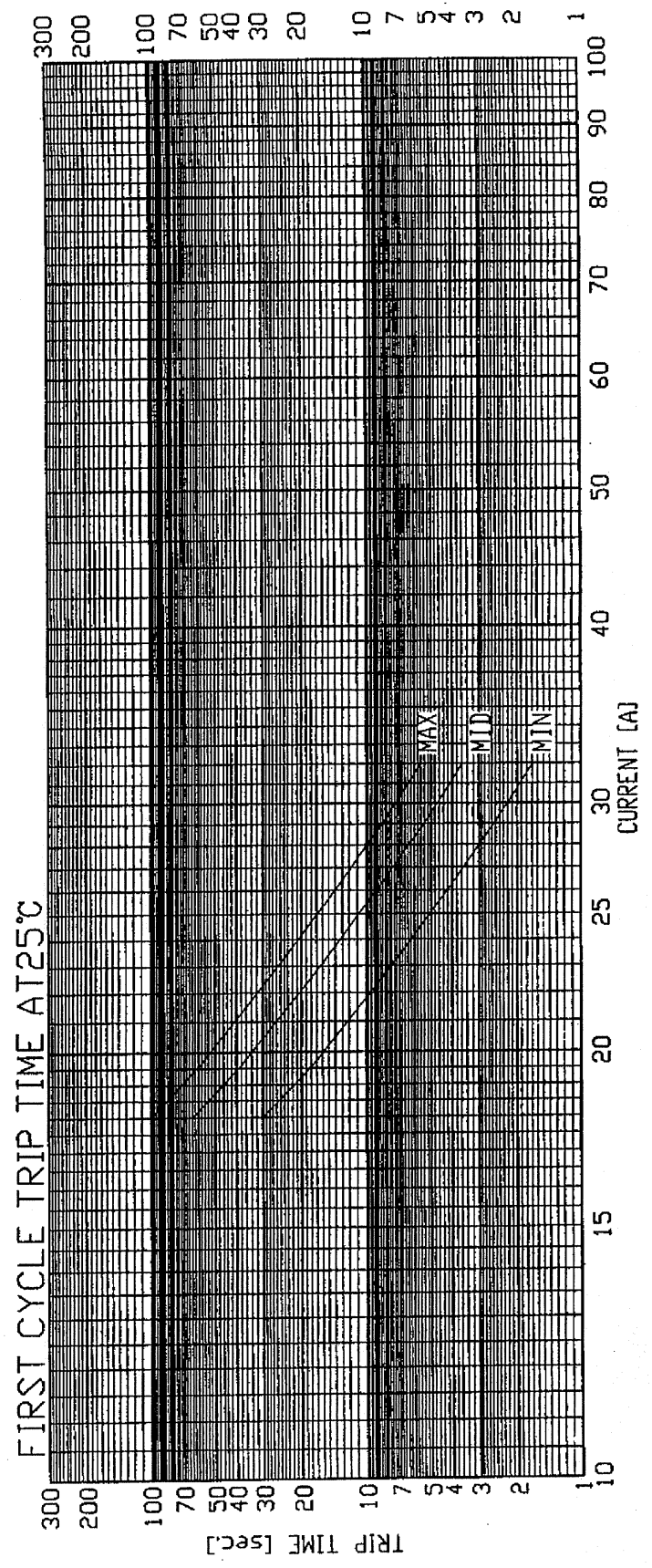
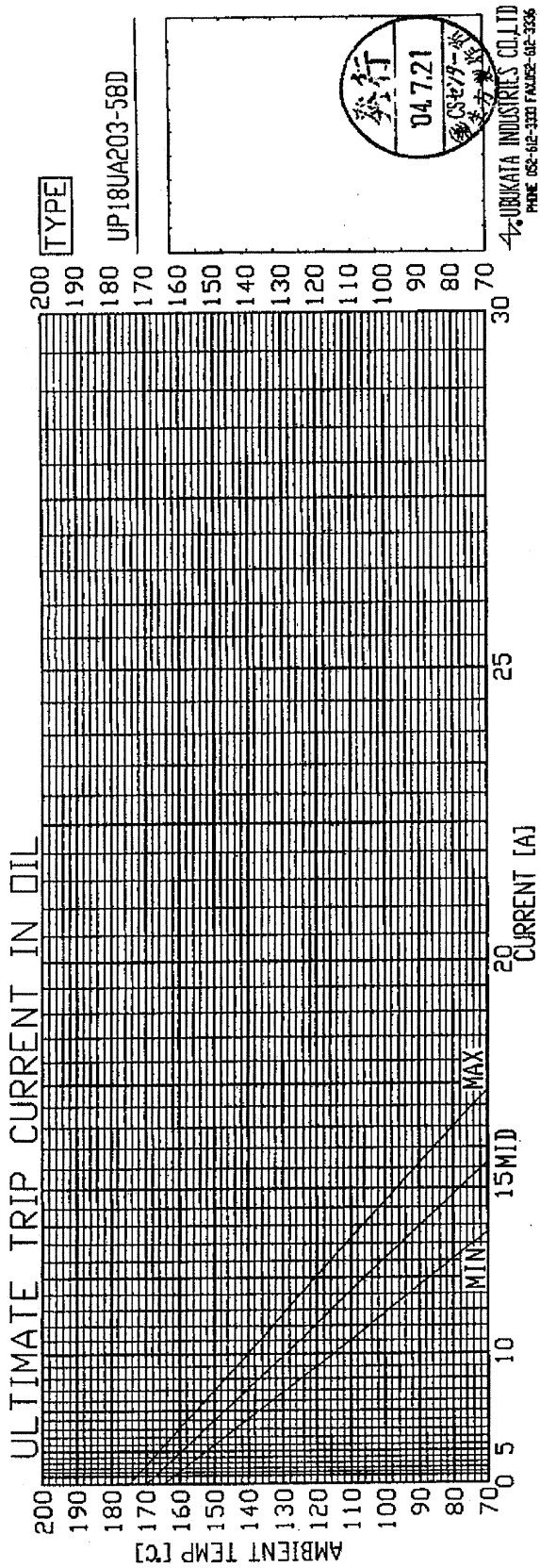

While install the compressor, Setting position of protection devices must be attention.

- Protection Devices : Low Pressure Switch
 High Pressure Switch
 Discharge Pipe Thermostat

	Setting Position	Notice
Low pressure switch	Compressor ~ Accumulator	Confirm discharge port temperature
High pressure switch	Compressor ~ Four-way Valve	
Discharge pipe thermostat	Distance from discharge pipe is 30cm (max)	Confirm discharge port temperature

Notice: The setting position must possibly close to the compressor.

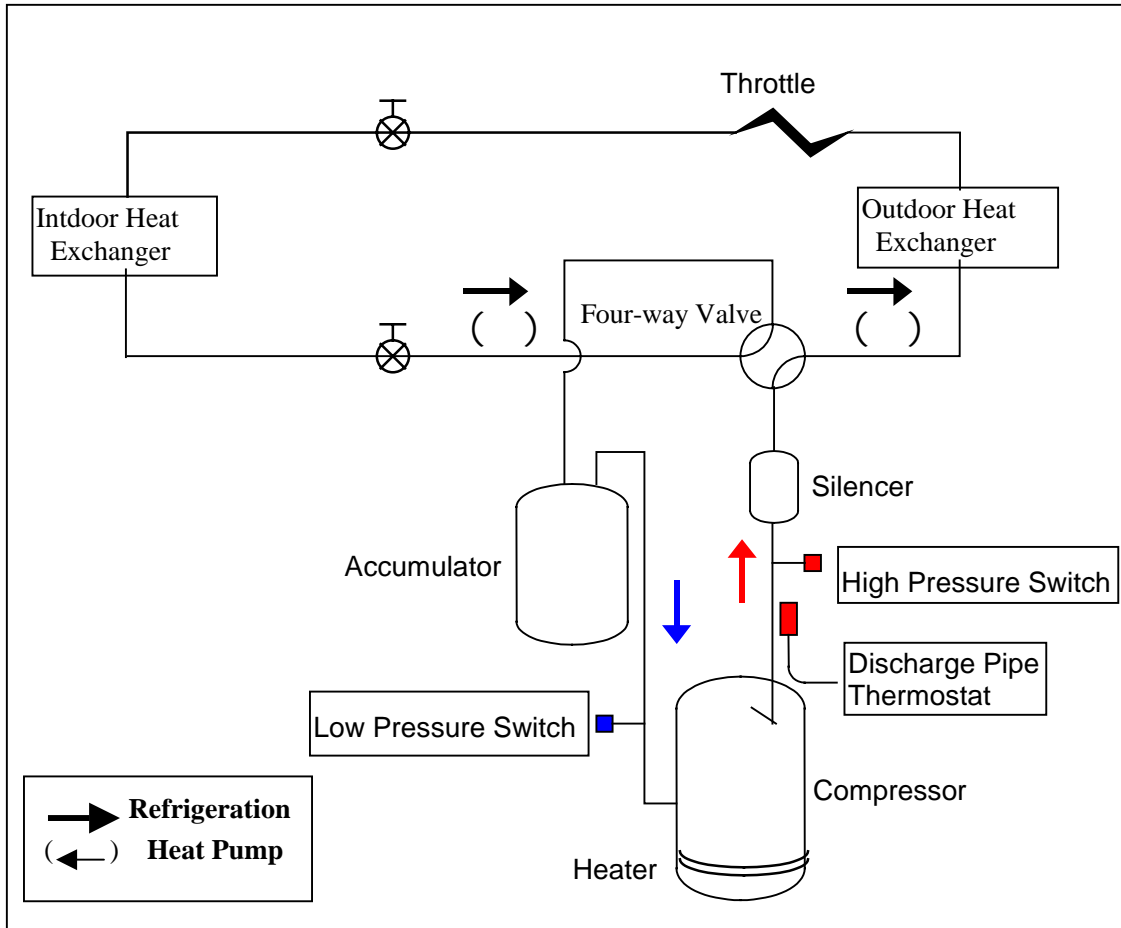

Reverse-Phase Protector

1 : Operating Condition

	Item	Used Condition
1	Installation Site	Inside Control Box of Indoor or Outdoor System
2	Operating Temperature	- 20 ~ 60
3	Storage Temperature	- 25 ~ 70
4	Humidity	Maximum Range 98%R.H., under 80%R.H. Year Average, under 80%R.H at 60 .Capable fluctuating Temperature or Humidity.

2 : Specification

	Item	Specification
1	Model	RPJ-400V
2	Function	Make: Positive – Phase – Sequence Break: Negative – Phase - Sequence
3	Rated Main Circuit Voltage	R-S-T1 AC 346V ~ 380V(3 Phase) R-S-T2 AC 400V ~ 440V(3 Phase)
4	Time Rating	Continuous
5	Output Contact Rating	AC 250V Inductive Load Making 8A(Pf=0.65), Breaking 2A(Pf=0.4) Resistive Load 3A(Pf=0.95 MIN.)
6	Life	10000 Times MIN.
7	Weight	37g
8	Applicable Mounting Spacers	XGLS-8S (Made By KITAGAWA INDUSTRY CO., LTD.) 4 pieces

3 : Dimension Diagram

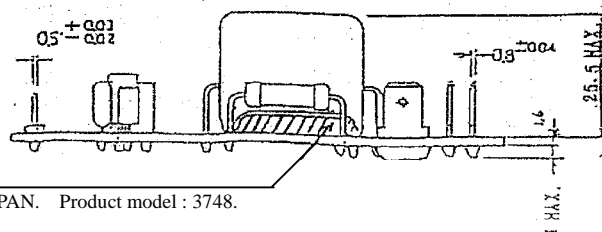
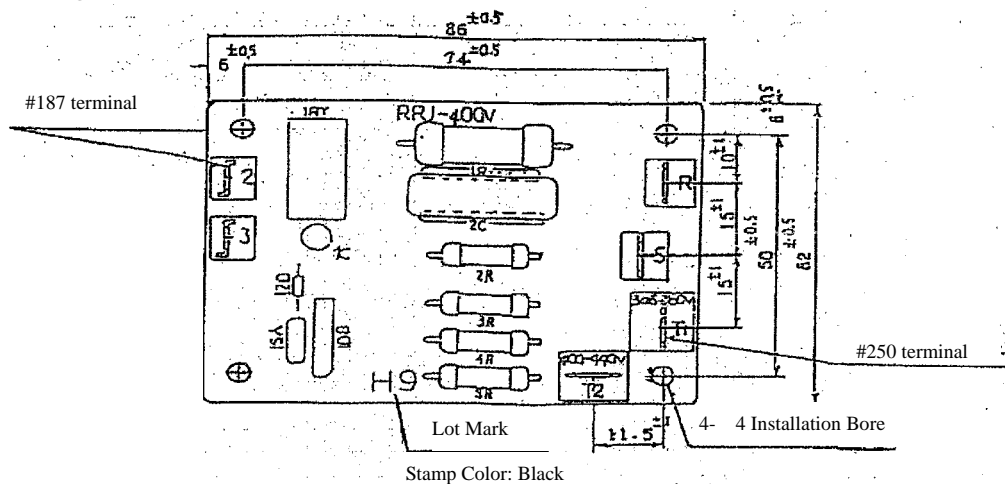

2C Capacitor: Fixed by Binder
Binder is made by SIMITOMO 3M, JAPAN. Product model : 3748.

4 : Circuit Diagram

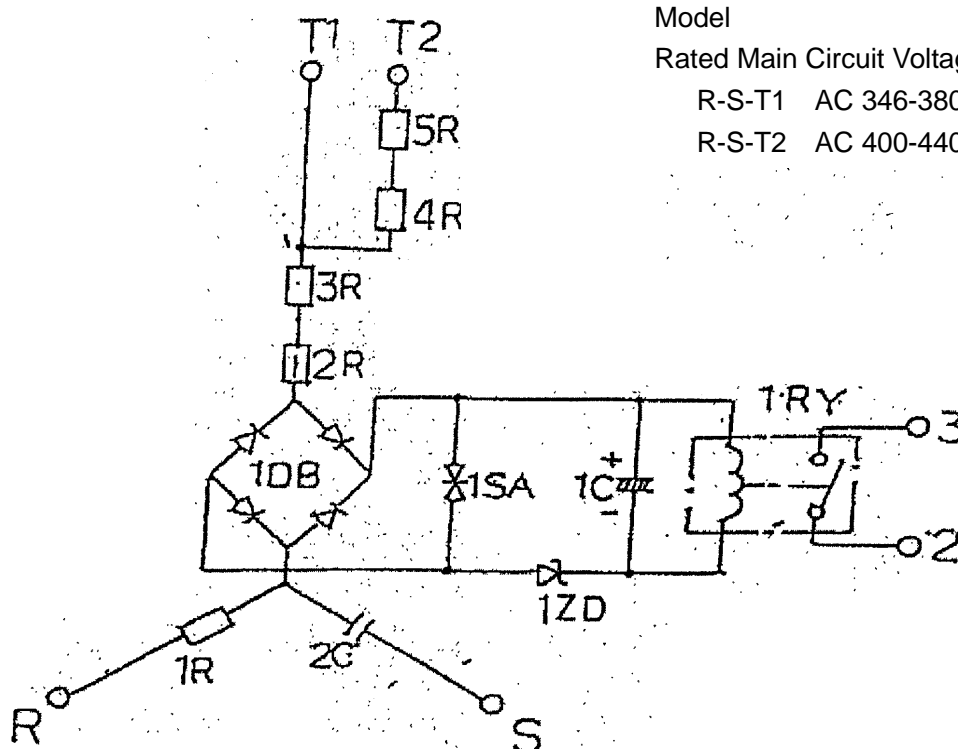

Model : PRJ-400V

Rated Main Circuit Voltage :

R-S-T1 AC 346-380V(50/60 Hz)

R-S-T2 AC 400-440V(50/60 Hz)

5 : Parts Table

.	Parts Name	Mark	Quantity	Specification
1	Resist-Oxidation Metal-film Resistor	1R	1	3W 82k
2	Resist-Oxidation Metal-film Resistor	2R	1	2W 5.6k
3	Resist-Oxidation Metal-film Resistor	3R	1	2W 5.6k
4	Resist-Oxidation Metal-film Resistor	4R	1	2W 5.6k
5	Resist-Oxidation Metal-film Resistor	5R	1	2W 5.6k
6	Electrolytic Capacitor	1C	1	50V 22 μ F
7	Metallized Polyester film Capacitor	2C	1	AC600V 0.039 μ F
8	Diode Subassembly	1DB	1	200V 1A
9	Rheostat	1SA	1	120V
10	Low-Voltage Diode	1ZD	1	500mV 24V
11	Relay	1RY	1	G6B-1114P-US, DC 24V(OMRON)
12	Printed Circuit Board	-	1	CEM-3, 94V-O
13	Terminal (#250)	-	4	Tinned Brass (0.8 T)
14	Terminal (#187)	-	2	Tinned Brass (0.5 T)



CAD/300
第3角投影法
3RD ANGLE PROJECTION

機 種 名 MODEL	JT100GBBY1L	JT95GBBY1L	JT90GBBY1L
定 額 出 力 RATED OUTPUT (KW)	2.2		
掃 引 ノ ケ 量 SWEEP VOLUME (cm ³ /rev)	49.8	49.4	45.8
定 格 回 転 速 度 RATED SPEED (r/min)	2900		
冷 凍 機 油 REF. OIL GRADE	DAPHNE FVC68D		
冷 凍 機 油 充 満 量 REF. OIL CHARGE (L)	1.2		
冷 媒 REFRIGERANT	R407C		
吸 入 側 接 続 SUCTION CONN	φ22.2 I.D. 銅メッキ20#		
吐 出 側 接 続 DISCHARGE CONN	φ15.9 I.D. C1220T-0		
質 量 (冷 凍 機 油 含 マ ス) NET WEIGHT (KG)	27.8		
電 源 POWER SUPPLY	3 PHASE 50 HZ		
電 圧 VOLTAGE RANGE (V)	3.80		

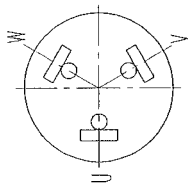

端子位置
PHASE ARRANGEMENT

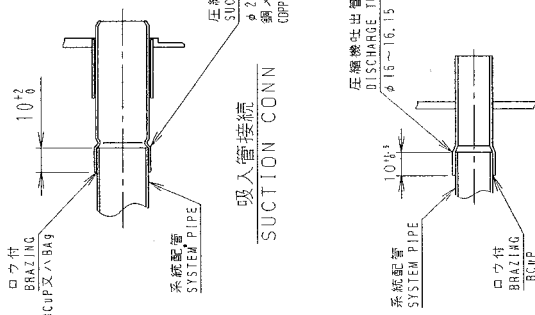
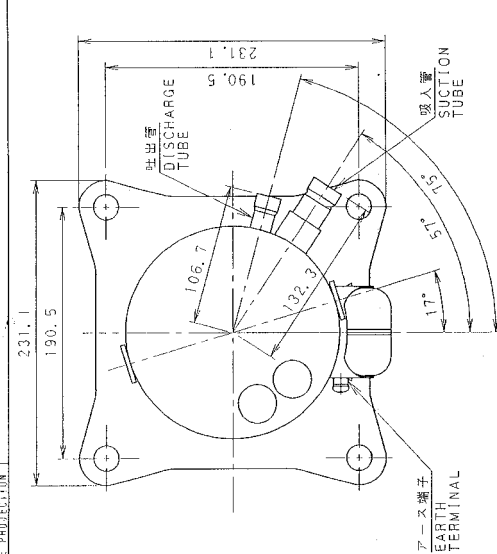

配線要領
WIRING DIAGRAM

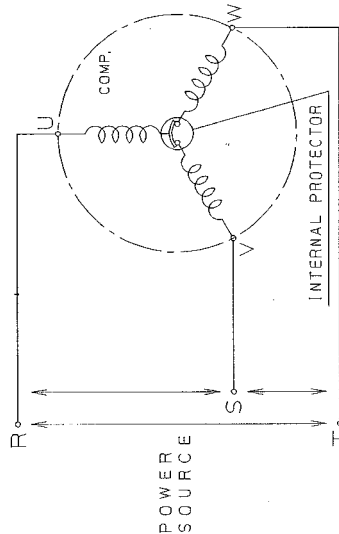

注) 1. 本寸法ハターミナル中心高サヲ示ス。
THIS HEIGHT DIMENSION SHOWS
THE CENTER LINE OF THE GLASS TERMINAL ASSY.

CCM	2
-----	---

塗 装 材 質 (Oで囲む) 00・10・20・ 50・60・70
--

新 規 設 計 指 導 者 名 杉 山

図 番 DRAW. NO.	DA27-2110
------------------	-----------

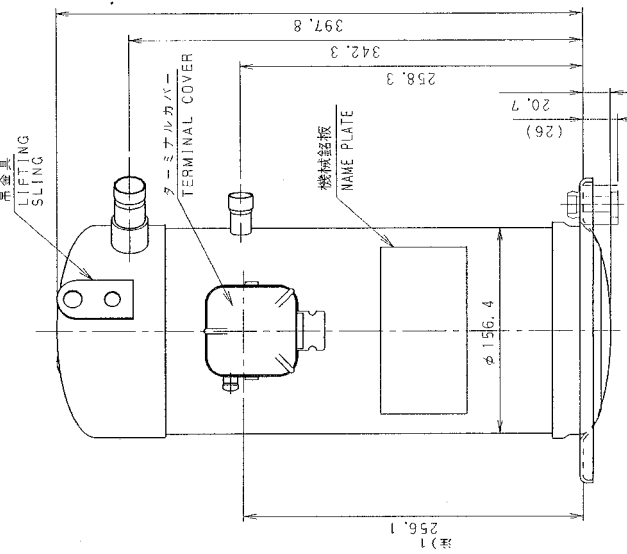

尺 寸 尺 寸 SCALE	名 称 NAME	製 品 コー ド PART CODE	外 形 図 EXTERNAL VIEW
作 成 日 DATE	図 番 DRAW. NO.	DA27-2110	JT100GBBY1L
発 注 番 号 ORDER NO.	製 作 数 QUANT.		
44.07.23			
DAIKIN 株式会社			
APPROVED / CHECKED / DESIGNED / DRAWN			
DAIKIN, INC.			

Crankcase Heater

- Install crankcase heater along weld mark upper as follow fig.
- Please don't let Crankcase heater cover the weld mark. (May result in insulation resistance fall.)
- Heater Specification

1. Output : $33W \pm 7\%$

2. Voltage : $200V \begin{matrix} +20\% \\ -10\% \end{matrix}$ or $240V \begin{matrix} +10\% \\ -20\% \end{matrix}$

3. Insulating performance (after put it in water for 24h)

* Withstand voltage: AC1500V for 1 min. and the insulator no broke through.

* Insulation Resistance :100M Min. (Test with DC 500V gauge for 1 min)

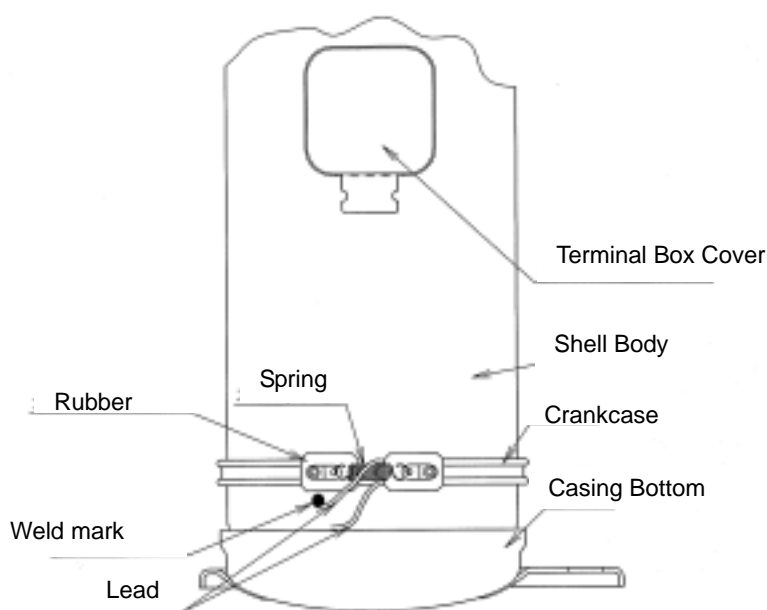
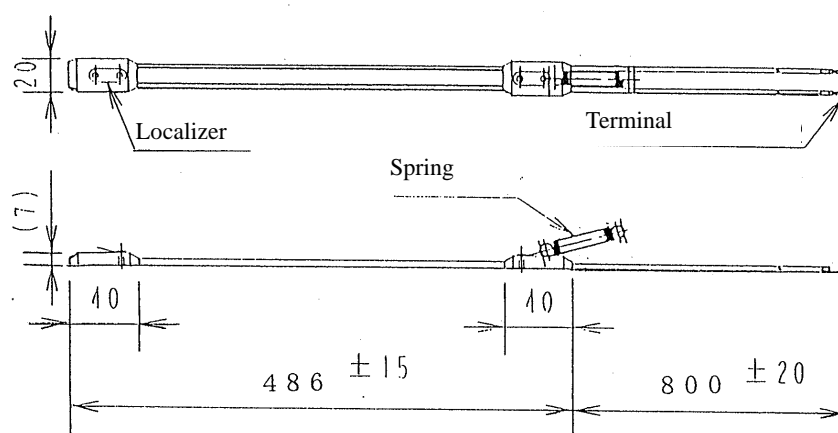

Manner of heater Installation

図番 DA 429-903 B	品名 PART NAME	数量* QTY	記 事 REMARK
	1 防振ゴム MOUNT. RUBBER	3 4	
	2 スパース SPAOER	3 4	鋼管 STEEL PIPE
	3 座金 WASHER	3 4	客先調達 CUSTOMER'S ARRANGE 72.6
	4 ボルト M8x45 BOLT	3 4	客先調達 CUSTOMER'S ARRANGE
	5 ナット M8 NUT	3 4	客先調達 CUSTOMER'S ARRANGE

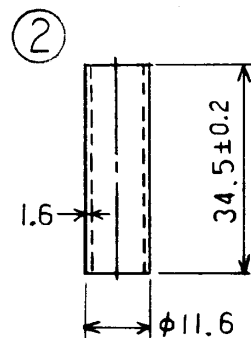
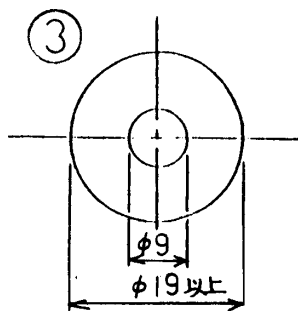

注) 圧縮機ニヨリ防振ゴムノ使用数ガ異ナル

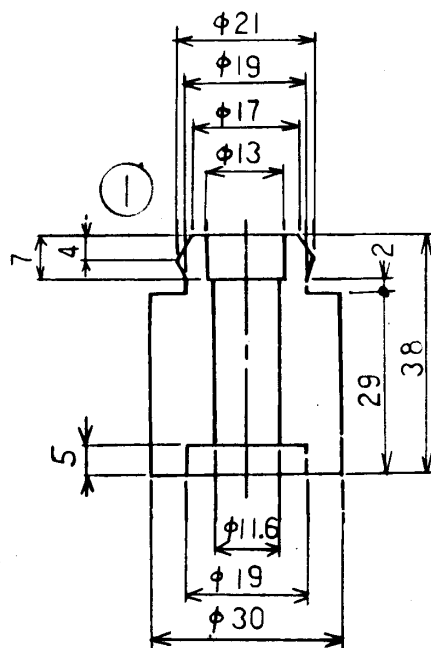
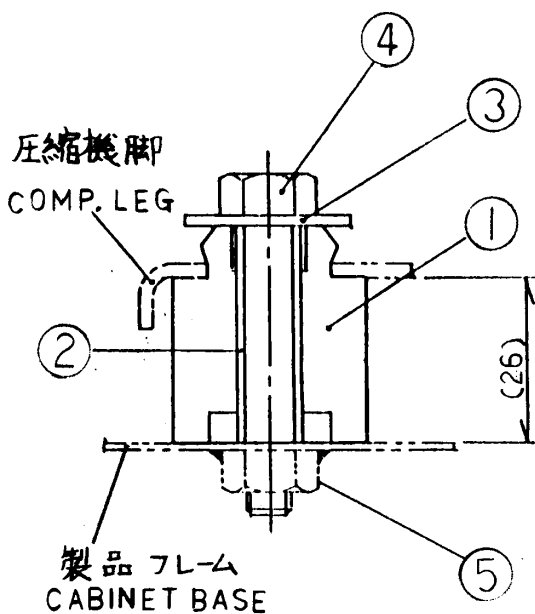

改正欄 REV.	
▲ 95.6.12	仕様変更 共通化17X
▲ 96.10.8	個数4並記

第3角法 3RD ANGLE PROJECTION	尺 度 SCALE	♂
作成日 DATE	YR 88. MO 9. DA	
承認 APPROVED	照 査 CHECKED	設 計 DESIGNED
		製 図 DRAWN

JT※A(B) 防振ゴム
MOUNT. PARTS

配 布 先

秘 的 場

西 川

ダイキン工業株式会社
DAIKIN INDUSTRIES LTD

図番 DWG. NO.

DA 429-903 B

Earthing Terminal

When earth with compressor earthing terminal, please operate as follow fig.

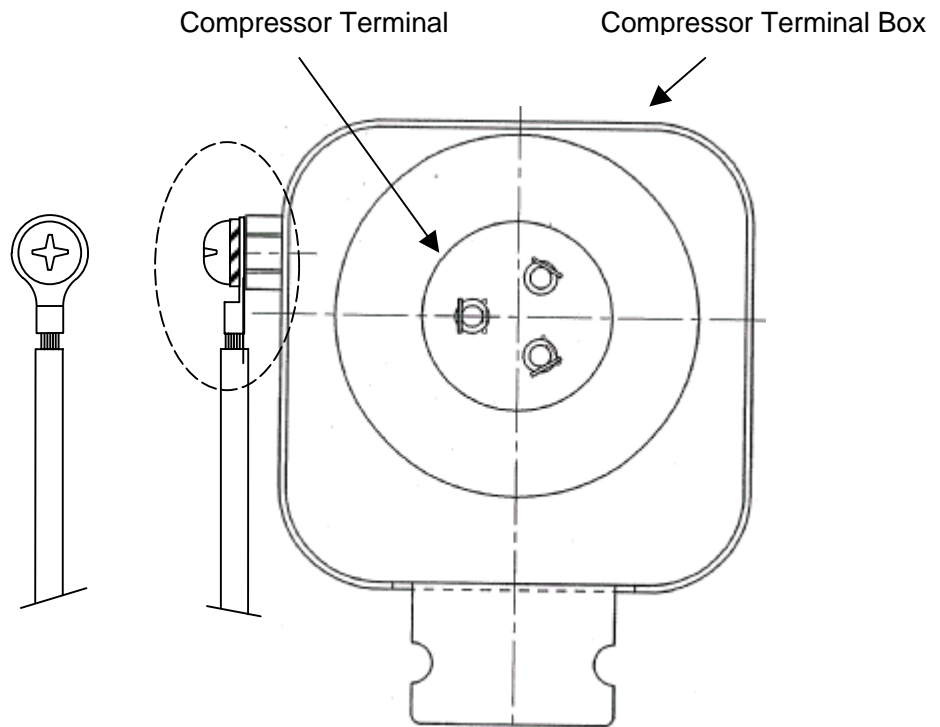

Earthing Terminal (Delivery under the M6 bolt and Terminal box is installed)

Ring Tongue Terminal (Purchase by buyer 、 Japanese tongue terminal 2-6 or similar)

Dentoid Washer For M6 (Purchase by buyer)

(Material: Stainless Steel, Model: GB862.1-87 or GB862.2-87)

Pan head screw with cross recess

M6 × 8 (Purchase by buyer)

(Material: Stainless steel、 Model:GB818-85)

Tighten torque:0.515N · m ± 15 %

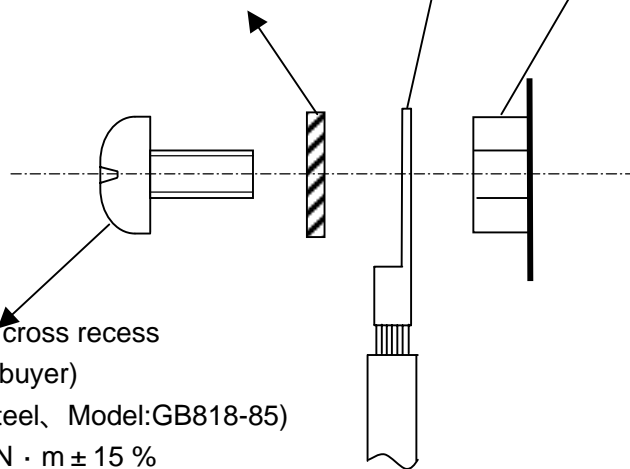

Detailed fig. of Earthing Terminal

図番 DRW. NO.

DA427-4446

TC: 55°C TE: 5°C CAPACITY 8.12 [kW] INPUT 2.83 [kW] CURRENT 4.9 [A]

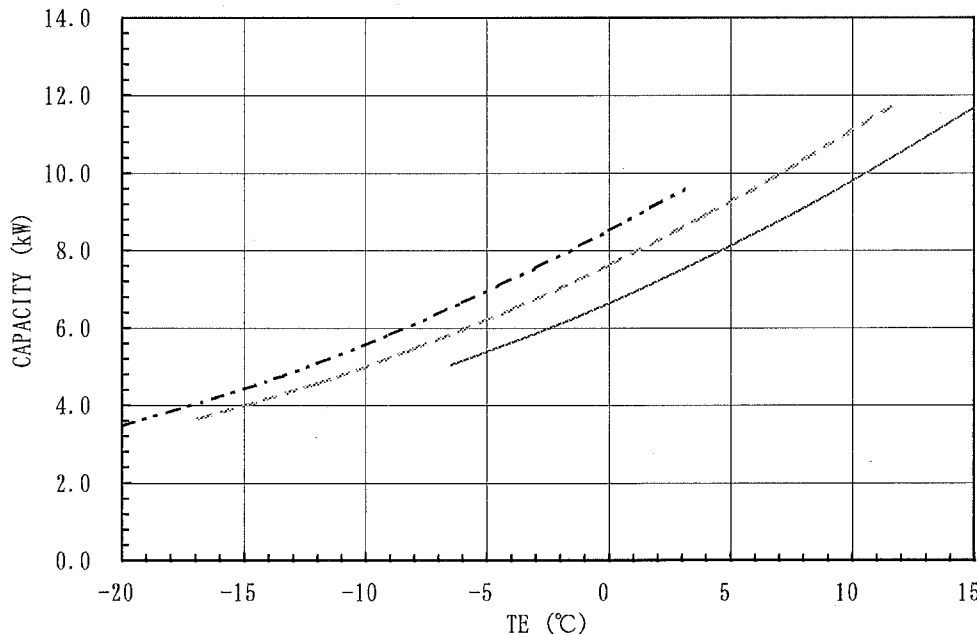
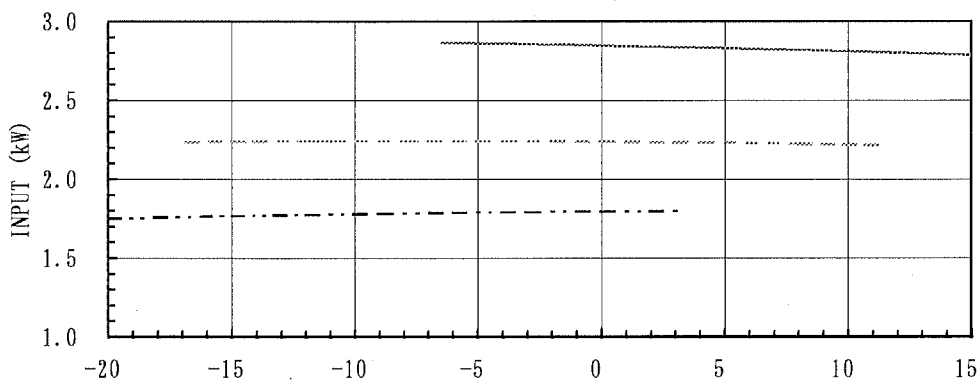
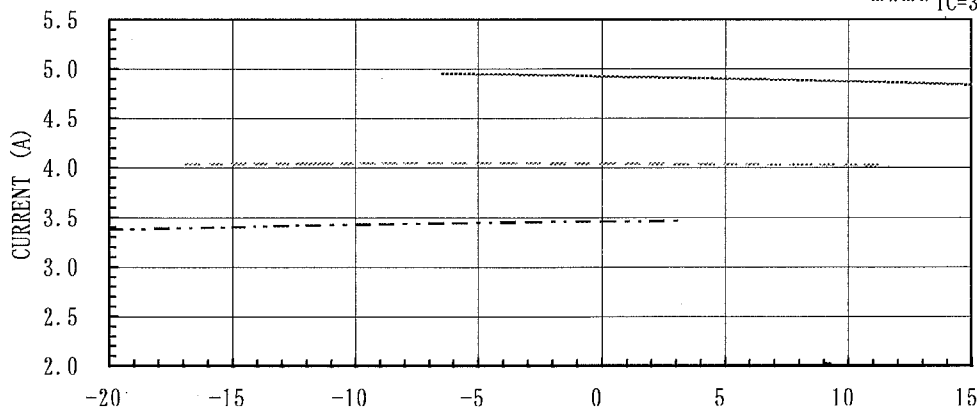

改正欄 REV.	
△	...
△	...
△	...
配布先	

第 3 角法 3RD ANGLE PROJECTION		尺度 SCALE		JT95GB-Y1L		PERFORMANCE CURVES	
作成日DATE YR 2004 MO 08 DA 30				380 V- 50Hz R407C		100% LOADING	
承認 APPROVED		照査 CHECKED		設計 DESIGNED		製図 DRAWN	
比 浦		野 島		杉 山		図 番 DRW. NO. DA427-4446	
ダイキン工業株式会社 DAIKIN INDUSTRIES LTD							

図番 DRW. NO.

DA427-4447

$$[\text{CAPACITY, INPUT, CURRENT}] = R(1) + R(2) * TC + R(3) * TE + R(4) * TC^2 + R(5) * TC * TE + R(6) * TE^2$$

TC=CONDENSING TEMP. (°C) TE=EVAPORATING TEMP. (°C)

380V- 50Hz R407C SH(°C) : 8 SC(°C) : 5 100% LOADING

	CAPACITY (kW)	INPUT (kW)	CURRENT (A)
R(1)	1.0892546E+01	1.5683224E+00	3.7395713E+00
R(2)	-5.1929437E-02	-2.2990663E-02	-5.9678510E-02
R(3)	4.4195691E-01	7.7214516E-03	1.4027544E-02
R(4)	-4.6033718E-04	8.4078551E-04	1.4767328E-03
R(5)	-3.0442909E-03	-1.9666716E-04	-3.3524493E-04
R(6)	4.1302484E-03	-6.9437112E-05	-9.2625633E-05

改正欄 REV.	
△	• •
△	• •
△	• •

第 3 角 法 3RD ANGLE PROJECTION	尺 度 SCALE
作成日DATE YR 2004 MO 08 DA 30	
承認 APPROVED	照査 CHECKED
設計 DESIGNED	製図 DRAWN

COEFFICIENTS OF PERFORMANCE CURVES
MODEL: JT95GB-Y1L

配布先

比 野 杉
爾 島 山

ダイキン工業株式会社
DAIKIN INDUSTRIES LTD

図番 DRW. NO.
DA427-4447